

PARTITION PLAT NO. 2025-07  
 INSTRUMENT NO. 2025-4212  
 IN THE SE 1/4 OF SECTION 23  
 & THE SW 1/4 OF SECTION 24,  
 T4N, R2W, W.M.,  
 COLUMBIA COUNTY, OREGON  
 MARCH 6, 2025

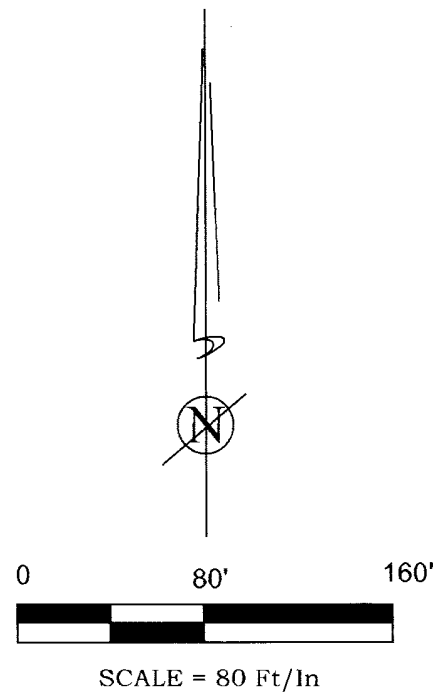

**FRANZ**  
 INSTRUMENT NO. 1989-6978 & 2013-007283  
**PARKS LIVING TRUST**  
 INSTRUMENT NO. 2023-00760

**FRANZ**  
 INSTRUMENT NO. 2009-010036

**MOORE**  
 INSTRUMENT NO. 2008-002925

**NELSON & TEWS**  
 INSTRUMENT NO. 2014-005674

2(N 88°45'02" E 1324.12')  
 5(N 88°45'26" E 1324.09')  
 S 89°10'15" E 1323.96'

N 89°10'15" W 1298.51'

N 89°10'15" W 1293.53'

**PARCEL 3**  
 5.06 Acres

N 89°10'15" W 1270.22'

**PARCEL 2**  
 5.18 Acres

N 88°47'33" W 861.17'

**PARCEL 1**  
 5.00 Acres

N 00°00'00" E 70.07'

N 89°08'58" W 410.66'

2(30.0')  
 N 00°22'08" E 29.92' [9887]  
 6(331.80') 331.70' [9886]  
 S 89°10'34" E 1272.35'  
 S 89°10'34" E 1301.82'  
 2(S 88°45'12" E 1301.89')  
 7(S 88°45'12" E 1301.73')

30' EASEMENT PER  
 BOOK 205, PAGE 941

2(599.71')  
 S 89°10'34" E 599.60'  
 6(570.44') 570.55'

N 89°10'34" W 600.02'

**NASTROM TREE FARM TRUST**  
 INSTRUMENT NO. 2019-010387

**PARCEL 1**  
 PARTITION PLAT NO. 2000-32

100.00' B.P.A. EASEMENT PER  
 DEED BOOK 67, PAGE 354

**RODNEY STREET**  
 (C.R. NO. P-308)  
 (60.00' RIGHT OF WAY WIDTH)

SEE SHEET 2  
 FOR DETAIL  
**FIVE PEAKS ESTATES**  
 ①

**LEGEND**

- FOUND MONUMENT AS NOTED
- SET A 5/8" X 30" IRON ROD WITH A Y.P.C. MARKED "KLS SURVEYING INC."
- [X] MONUMENT POINT NO
- ( ) RECORD SURVEY DATA
- [ ] RECORD DEED DATA
- CS NO. SURVEY NUMBER, COLUMBIA COUNTY SURVEY RECORDS
- Y.P.C. YELLOW PLASTIC CAP

**REFERENCES:**

- |                                |                                |
|--------------------------------|--------------------------------|
| <b>SURVEYS</b>                 | <b>DEEDS</b>                   |
| 1 = CS NO. 2760                | 1 = INSTRUMENT NO. 1998-6978   |
| 2 = CS NO. L-1469              | 2 = INSTRUMENT NO. 2008-002925 |
| 3 = B.T. BOOK C, PAGE 451      | 3 = INSTRUMENT NO. 2009-010036 |
| 4 = FIVE PEAKS ESTATES         | 4 = INSTRUMENT NO. 2013-007823 |
| 5 = WOODS HEIGHTS              | 5 = INSTRUMENT NO. 2014-005674 |
| 6 = PARTITION PLAT NO. 2000-32 | 6 = INSTRUMENT NO. 2019-010387 |
| 7 = CS NO. 4326                | 7 = INSTRUMENT NO. 2023-00760  |
| 8 = CS NO. 5505                | 8 = INSTRUMENT NO. 2023-06118  |
| 9 = CS NO. 5626                |                                |

REGISTERED PROFESSIONAL LAND SURVEYOR  
  
 OREGON  
 JANUARY 19, 1993  
 DONALD D. WALLACE, JR.  
 2601  
 RENEWS 6/30/26

**K.L.S. SURVEYING INC.**  
 1224 ALDER STREET  
 VERNONIA, OREGON 97064  
 (503) 429-8115

**SHEET 1 OF 3**

JOB No. WARREN
DRAWING NAME: 23-313 S1
DRAWN BY: ORM
FIELD: SWMJR/CAM
EQUIPMENT: NOMAD/NIKON
REVISED: 7-2-2025



PARTITION PLAT NO. 2025-07  
 INSTRUMENT NO. 2025-4212  
 IN THE SE 1/4 OF SECTION 23  
 & THE SW 1/4 OF SECTION 24,  
 T4N, R2W, W.M.,  
 COLUMBIA COUNTY, OREGON  
 MARCH 6, 2025

**COLUMBIA COUNTY APPROVALS:**

APPROVED THIS 10<sup>th</sup> DAY OF July, 2025  
 COLUMBIA COUNTY PLANNING DEPARTMENT  
 BY [Signature]

APPROVED THIS 14 DAY OF July, 2025  
 COLUMBIA COUNTY SURVEYOR  
 BY Nathan A. Woodward

ALL TAXES, FEES, ASSESSMENTS OR OTHER CHARGES AS PROVIDED BY  
 ORS 92.095 HAVE BEEN PAID AS OF THIS 14<sup>th</sup> DAY OF  
July 2025

COLUMBIA COUNTY TAX COLLECTOR  
 BY [Signature]

STATE OF OREGON )  
 ) SS  
 COUNTY OF COLUMBIA )

I DO HEREBY CERTIFY THAT THIS PARTITION PLAT WAS RECEIVED  
 FOR RECORD ON THIS 14 DAY OF July, 2025, AT  
2:38 O'CLOCK PM, AND RECORDED AS INSTRUMENT NO. 2025-4212  
 AND AS PARTITION PLAT NUMBER 2025-07, COLUMBIA COUNTY RECORDS

BY [Signature]  
 COLUMBIA COUNTY CLERK, Deputy

**NOTES:**

1.) THIS PLAT IS SUBJECT TO THE TERMS AND CONDITIONS PER CASEFILE  
 NO. MP 24-04

APPROVED THIS 14 DAY OF July, 2025  
 COLUMBIA COUNTY BOARD OF COMMISSIONERS

BY: [Signature]  
 BY: [Signature]  
 BY: NOT PRESENT

**SURVEYOR'S CERTIFICATE:**

I, DONALD D. WALLACE, JR., DO HEREBY CERTIFY THAT I HAVE  
 CORRECTLY SURVEYED AND MARKED WITH PROPER MONUMENTS, IN  
 ACCORDANCE WITH ORS CHAPTER 92, PARCELS 1, 2, & 3, IN THE  
 SOUTHEAST QUARTER OF SECTION 23, TOWNSHIP 4 NORTH, RANGE 2 WEST  
 OF THE WILLAMETTE MERIDIAN, COLUMBIA COUNTY, OREGON, THE  
 BOUNDARY BEING MORE PARTICULARLY DESCRIBED AS FOLLOWS:

BEGINNING AT THE INITIAL POINT, BEING A 5/8" IRON ROD, AT THE  
 NORTHEAST CORNER OF WOODS HEIGHTS, COLUMBIA COUNTY RECORDS,  
 THENCE SOUTH 00°05'02" EAST ALONG THE EAST LINE OF SAID WOODS  
 HEIGHTS, 520.91 FEET TO THE SOUTHWEST CORNER OF THAT TRACT OF  
 LAND CONVEYED TO DAN & HOLLY HIGGINS IN DEED RECORDED AS  
 INSTRUMENT NO. 2023-06118, COLUMBIA COUNTY DEED RECORDS; THENCE  
 SOUTH 89°10'34" EAST ALONG THE SOUTH LINE OF SAID HIGGINS TRACT  
 1301.82 FEET TO THE SOUTHEAST CORNER THEREOF; THENCE NORTH 00°  
 26'54" WEST ALONG THE EAST LINE OF SAID HIGGINS TRACT 520.86 FEET TO  
 THE NORTHEAST CORNER THEREOF; THENCE NORTH 89°10'15" WEST ALONG  
 THE NORTH LINE OF SAID HIGGINS TRACT 1298.51 FEET TO THE INITIAL  
 POINT.

CONTAINING 15.54 ACRES MORE OR LESS.

**NARRATIVE:**

--THIS SURVEY WAS COMPLETED AT THE REQUEST OF BRAD HENDRICKSON  
 TO PARTITION THAT TRACT OF LAND CONVEYED TO DAN HIGGINS & HOLLY  
 FLEET HIGGINS IN DEED RECORDED AS INSTRUMENT NO. 2023-06118,  
 COLUMBIA COUNTY DEED RECORDS INTO PARCELS 1, 2, & 3.

--THE BASIS OF BEARINGS IS OREGON COORDINATE REFERENCE SYSTEM  
 COLUMBIA RIVER WEST ZONE, NAD83 (2011) EPOCH 2010.00. DISTANCES  
 SHOWN ARE GROUND DISTANCES.

--FOR CONTROL I HELD THE MONUMENTS AS NOTED IN THE MONUMENT  
 NOTES.

INSTRUMENT NO. 2023-06118:  
 --I HELD MONUMENTS 5128 AND 5118 FOR THE NORTH LINE. I HELD  
 MONUMENTS 4101 AND 5123 FOR THE SOUTH LINE. I HELD MONUMENTS  
 5143 AND 4104 FOR THE EAST LINE AND COMPUTED THE SE CORNER AT  
 THE INTERSECTION OF THE SOUTH LINE AND THE EAST LINE. I HELD  
 MONUMENTS 5123, 5125 AND 5128 FOR THE WEST LINE.

**MONUMENT NOTES:**

[4101]  
 NE CORNER PARCEL 1, PARTITION PLAT 2000-32.  
 FOUND A 5/8" IRON ROD WITH A Y.P.C. MARKED "MARTINEZ PLS 2536" PER  
 PARTITION PLAT NO. 2000-32, (HELD)

[4102]  
 FOUND A 1" IRON ROD PER CS NO. L-1469 DISTURBED THE MONUMENT LIES S  
 17°11'03" W 0.42' FROM THE TRUE CORNER.

[4103]  
 FOUND A 5/8" IRON ROD PER FIVE PEAKS ESTATES, (HELD)

[4104]  
 FOUND A RAILROAD SPIKE PER CS NO L-1469, (HELD)

[5118]  
 1/4 CORNER COMMON TO SECTIONS 23 & 24  
 FOUND A 1" IRON PIPE WITH MUSHROOM TOP PER B.T. BOOK C, PAGE 451,  
 (HELD)

[5123]  
 FOUND A 1" IRON PIPE DOWN 0.50' PER CS NO. L-1469, (HELD)

[5125]  
 FOUND A 5/8" IRON ROD WITH A Y.P.C MARKED "BRADY LS 1860" PER WOODS  
 HEIGHTS, MONUMENT LIES S 89°54'34" W 0.13' FROM THE WEST LINE

[5128]  
 NE CORNER OF LOT 5, WOODS HEIGHTS  
 FOUND A 5/8" IRON ROD PER CS NO. 2760, (HELD)

[5143]  
 FOUND A 5/8" IRON ROD PER FIVE PEAKS ESTATES, (HELD FOR EASTING)  
 MONUMENT LIES S 0°26'54" W 0.69' FROM THE NORTH LINE OF THE SE  
 QUARTER OF SECTION 23.

[6100]  
 FOUND A 5/8" IRON ROD WITH A Y.P.C. MARKED "KLS SURVEYING INC" PER CS  
 NO. 5505. DISTURBED BY NEW FENCE POST, THE MONUMENT LIES N 00°49'45"  
 E 0.25' FROM LINE.

[6101]  
 FOUND A 5/8" IRON ROD WITH A Y.P.C. MARKED "KLS SURVEYING INC" PER CS  
 NO. 5626. (HELD)

[6102]  
 FOUND A 5/8" IRON ROD WITH A Y.P.C. MARKED "KLS SURVEYING INC" PER CS  
 NO. 5505. DISTURBED BY NEW FENCE POST, THE MONUMENT LIES N 00°49'45"  
 E 0.23' FROM LINE.

[6103]  
 FOUND A 5/8" IRON ROD WITH A Y.P.C. MARKED "KLS SURVEYING INC" PER CS  
 NO. 5505. (HELD)

[9686]  
 FOUND A 1" IRON PIPE PER CS L-1469. (HELD)

[9887]  
 FOUND A 3/4" IRON PIPE PER CS L-1469. (HELD)

[9889]  
 NW CORNER PARCEL 1, PARTITION PLAT 2000-32  
 FOUND A 5/8" IRON ROD WITH A Y.P.C. MARKED "LS 2536" PER CS NO. 4326.  
 (HELD)

**DECLARATION:**

KNOW ALL PEOPLE BY THESE PRESENTS THAT DAN HIGGINS & HOLLY FLEET  
 HIGGINS, ARE THE OWNERS OF THE LAND REPRESENTED ON THE ANNEXED  
 PLAT, AND MORE PARTICULARLY DESCRIBED IN THE ACCOMPANYING  
 SURVEYOR'S CERTIFICATE, AND THEY HAVE CAUSED THE SAME TO BE  
 SURVEYED AND PARTITIONED INTO PARCELS 1, 2, & 3 AS SHOWN ON THE  
 ANNEXED PARTITION PLAT IN ACCORDANCE WITH O.R.S. CHAPTER 92 AND DO  
 HEREBY DEDICATE THE ADDITIONAL RIGHT OF WAY TO THE PUBLIC.

[Signature] DAN HIGGINS  
[Signature] HOLLY FLEET HIGGINS

[Signature]  
 BRAD HENDRICKSON

**ACKNOWLEDGEMENT:**

STATE OF OREGON )  
 Deschutes ) SS  
 COUNTY OF COLUMBIA )

THIS INSTRUMENT WAS ACKNOWLEDGED BEFORE ME ON  
May 20, 2025 BY DAN HIGGINS & HOLLY FLEET HIGGINS

[Signature]  
 NOTARY SIGNATURE  
[Signature]  
 NOTARY PUBLIC - OREGON

COMMISSION NO. 1048029  
 MY COMMISSION EXPIRES May 07, 2028

STATE OF OREGON )  
 ) SS  
 COUNTY OF COLUMBIA )

THIS INSTRUMENT WAS ACKNOWLEDGED BEFORE ME ON  
July 14<sup>th</sup>, 2025 BY BRAD HENDRICKSON

[Signature]  
 NOTARY SIGNATURE  
[Signature]  
 NOTARY PUBLIC - OREGON (PRINTED)

COMMISSION NO. 251772, MY COMMISSION EXPIRES 9/22/28

REGISTERED PROFESSIONAL LAND SURVEYOR <u>[Signature]</u> OREGON JANUARY 19, 1993 DONALD D WALLACE, JR 2601 RENEWS 6/30/26		SHEET 3 OF 3 JOB No. WARREN DRAWING NAME: 23-313 S2 DRAWN BY: ORM FIELD: SWM/JR/CAM EQUIPMENT: NOMAD/NIKON REVISED: 4-14-2025
K.L.S. SURVEYING INC. 1224 ALDER STREET VERNONIA, OREGON 97064 (503) 429-6115		